



TANK CLEANING TECHNOLOGIES

1-281-480-4041

#1 Tank Cleaning Machine in the Ethanol Industry

- Address: 15200 Middlebrook Drive, Suite E Houston, Texas, 77058, USA.
- Phone: 281.480.4041 • Fax: 713.513.5868
- E-Mail: sales@tankcleantech.com

Here's an edrawing showing the upper end of the external drive SC40RT for your review:

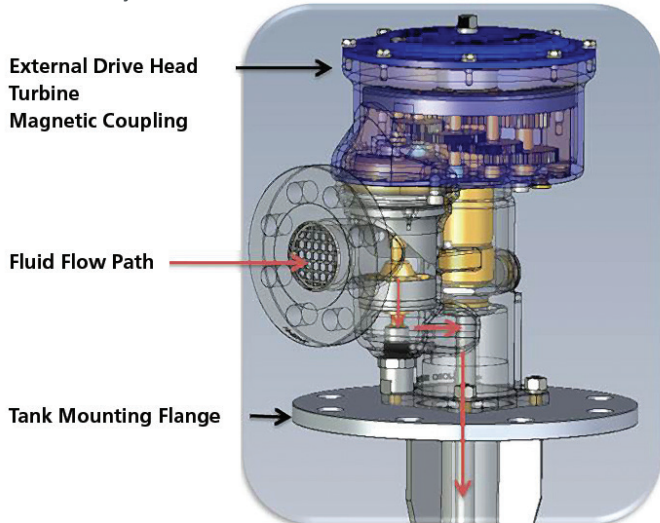

Industry Focus: Ethanol

SC40RT

External Drive Tank Cleaning Machine



www.tankcleantech.com

"External drive" means the gearbox and most essential components reside outside the tank. Your tank cleaners, or what we refer to as "conventional" or "internal drive" tank cleaning machines, have all essential working parts in the tank.

If there is an issue such as plugging or breakdown of a conventional machine, maintenance will have to pull the entire standpipe and machine combination every time (difficult job generally requiring at least 2 people... hard on operator's bodies especially in extreme weather conditions).

With the SC40RT, if there is a problem, everything can be handled from the top of the tank within minutes.

see reverse side for more info ...



SC40RT Ethanol References:

Doug Hennie

NorAmera BioEnergy Corporation
Maintenance Coordinator
(306) 842-3922 Work | (306) 861-3902 Work
dhennie@noramera.com
#60 Queens Street | Weyburn, SK S4H 2L2
www.noramera.com

Joe Kreutzer

Prairie Horizon Agri-Energy, LLC
Plant Manger
(785) 543-6719 Work | (785) 302-0484 Mobile
jkreutzer@phaellc.com
1664 E. 100 Rd. | Phillipsburg, KS 67661
www.phaellc.com

Duaine Tittel

Western Plains Energy LLC
Maintenance Manager
(785) 672-8810 Work | (785) 672-2636 Mobile
dtittel@wpellc.com
3022 Country Road 18 | Oakley, KS 67748
www.wpellc.com

Josh Edwards

Noble Americas South Bend Ethanol
Plant Manager
(219) 233-3116 Work | (316) 347-0939 Work
Josh.Edwards@icminc.com
P.O. Box2289 | South Bend, IN 46680-2289
www.icminc.com

Jayson Verbeck

ICM, Inc.
Project Manager
(316) 796-0900 Work | (316) 977-6244 Work
jayson.verbeck@icminc.com
310 N. First Street | Colwich, KS 67030
www.icminc.com

Alex Martinez

Pinal Energy LLC
Maintenance Manager
(520) 494-2400 Work | (520) 483-3783 Mobile
amartinez@pinalenergyllc.com
38585 West Cowtown Road | Maricopa, AZ 85139
www.pinalenergyllc.com

Some other advantages of the "external drive" SC40RT vs. "conventional internal drive" tank cleaning machines are as follows:

1. The SC40RT can handle 3 - 5+ times the solids so less likelihood of any stoppage due to plugging.
2. Harder hitting jet streams with pressure losses through the SC40RT under 3% vs. 20+% with conventional internal drives...this ultimately means better cleaning.
3. Very solidly built and reliable. One ethanol plant just went 7 years before recently needing some minor repairs. Outside of the ethanol industry, We currently have 100,000+ external drive machines working super reliably in harsh marine environments on chemical, oil, and product tankers around the world.
4. Majority of potential wear parts sit outside the tank so pulling the machines from the tank for maintenance is not required... Majority of maintenance can be done from the top of the tank. Changing entire gearbox out is a 10 minute job.
5. A completely sealed, magnetic-drive transmission design prevents exposure to tank contents.

